

*"The Wine and Cheer Cart"®*

[MODEL # WCC-6066]



**BEVERAGE CAPACITY**

Upper Basket - Grid Engaged: (14) Rings: Ten rings @ 1L / 750ML, Two Rings @ 1.75ML, Two Rings @1.5ML

Upper Basket - Grid Not Engaged: Approximately Thirty 750ML Bottles Standing Upright.

Rear Basket: Eight Bottles @ 750ML or Three Bottles @ 1.75ML or Two Twelve Packs.

Lower Tray: Six 30-Packs or Four Cases of Wine.

Nesting Distance: 10"

Weight: 55 Lbs.

**FEATURES/OPTIONS**

Assortment of Powder Coated Colors

Corner Bumpers

Handle with Logo

5" Non-Marking Wheels

# Wine and Cheer Cart

Model: WCC-6066 Specs

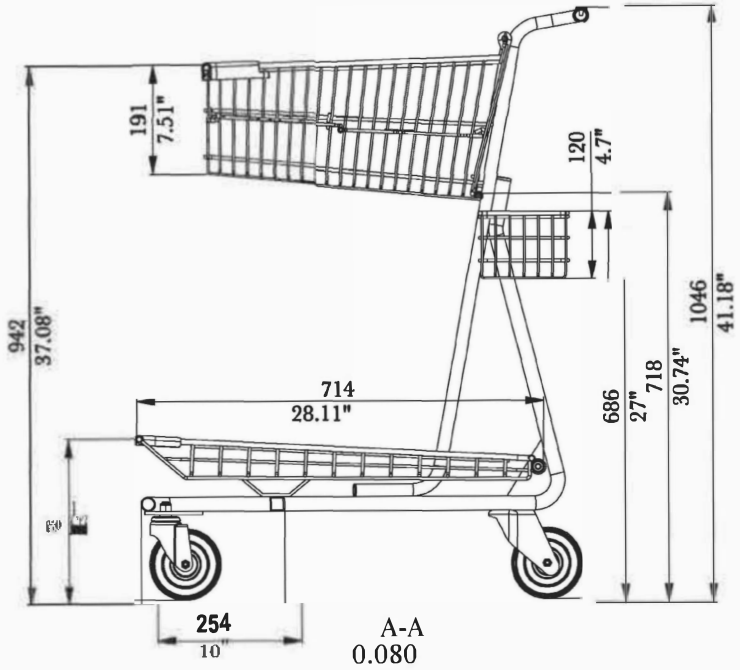

A-A  
0.080

794

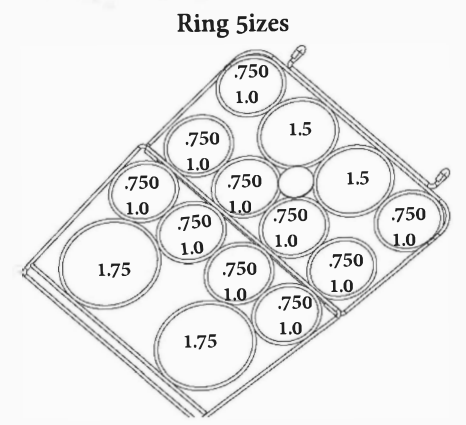
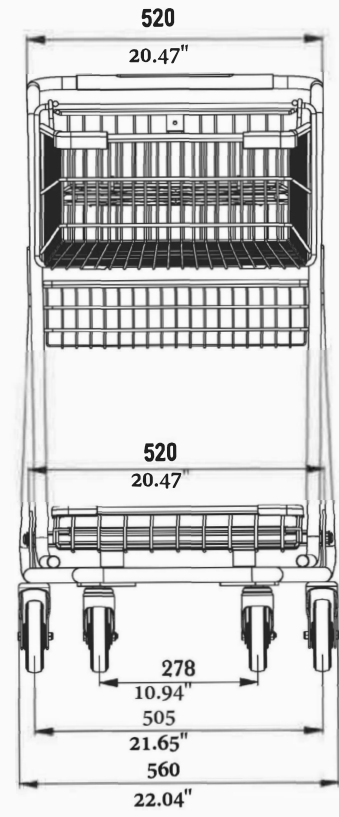
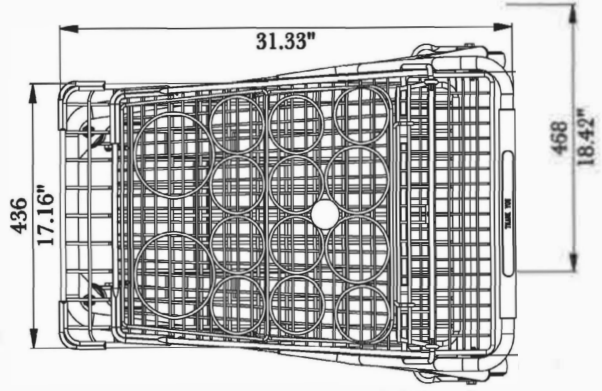

S 2022-01-13